

AUTOMATISMI PROFESSIONALI PER CANCELLI E GARAGE

PARTI DI RICAMBIO - SPARE PARTS - PIECES DE RECHANGE - ERSATZTEILE - PIEZAS DE REPUESTO - VERVANGINGSONDERDELEN - PECAS SOBRESSELENTES

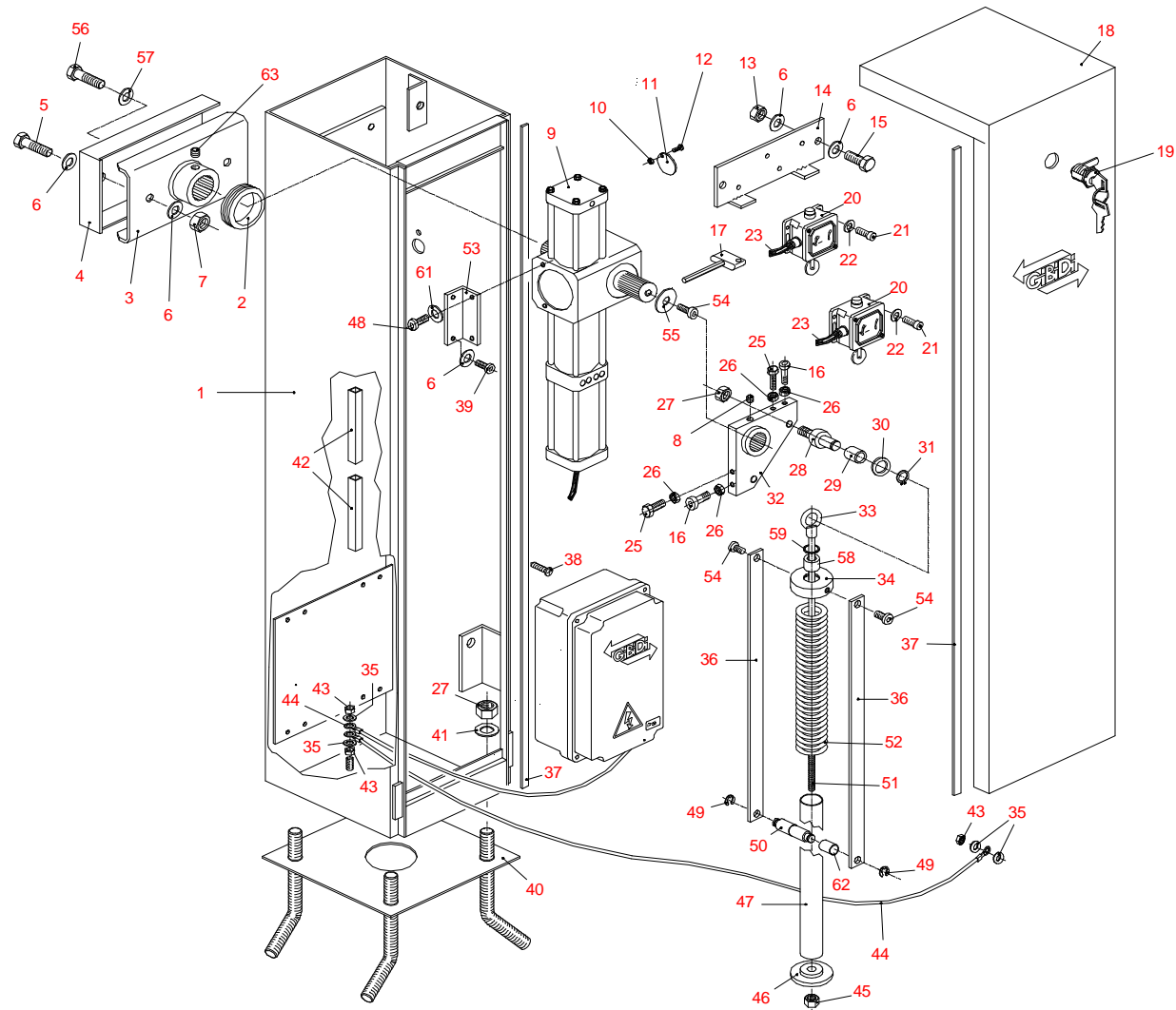

Gi.Bi.Di. Continental S.p.A. - 46025 Poggio Rusco (MN) - Via A. Brennero 177/B
Tel. ++39.045.8270511 - Fax ++39.045.8270527 - E-mail: comm.gibidi@pn.itnet.it



AUTOMATISMI PROFESSIONALI PER CANCELLI E GARAGE

PARTI DI RICAMBIO - SPARE PARTS - PIÈCES DE RECHANGE - ERSATZTEILE - PIEZAS DE REPUESTO - VERVANGINGSONDERDELEN - PECAS SOBRESSELENTES

Cod.	Descrizione Description Description Beschreibung	Descrìpçìon Beschrijving Descrição	
A90195P	Chiave ricambio L=80 mm Spare key L = 80mm Clé de rechange L=80 mm Ersatzschlüssel L=80 mm	Llave recambio L=80 mm Chave sobresselente L=80 mm Vervangende sleutel L = 80 mm	17 1
A90229P	Innesto braccio per Modo Arm coupling - Enclenchement bras Schaltkupplung Arm für Modo 600L/800	Conexión brazo Engate braço para Modo Armkoppeling voor Modo	3 1 4 1 5 2 6 4 7 2 56 1 57 1 63 1
A90231P	Coperchio mobile Barriera Complete mobile cover - barrier Couvercle mobile Barrière complet kompletter Schrankenkastendeckel	Cubierta mueble barrera completa Tampa móvel Barreira Beweegbaar deksel barrière	18 1 19 1
A90232P	Serratura mobile barriera Mobile barrier lock Serrure mobile barrière Schloß Schrankenkasten	Cerradura mueble barrera Trinco móvel barreira Beweegbaar slot barrière	19 1
A90234P	Finecorsa barriera Barrier limit switch Fin de course barrière Endschalter Schranke	Final de carrera barrera Fim de curso barreira Eindschakelaar barrière	20 1 21 2 22 2 23 1
A90235P	Camme finecorsa barriera Limit switch cams - Barrier Cames fin de course barrière Nocken Endschalter Schranke	Leva final de carrera barrera Came fim de curso barreira Nokken eindschakelaar barrière	8 1 16 2 25 2 26 4 27 1 28 1 29 1 30 1 31 1 32 1 54 1 55 1
A90236P	Viti fissaggio mobile barriera Fixing screws - barrier mobile base Vis de fixation mobile barrière Feststellschrauben Schrankenkasten	Tornillos de fijación mueble barrera Parafusos de fixação móvel barreira Bevestigingsschroeven beweegbare basis barrière	27 4 41 4
A90237P	Molla bilanciamento barriera 4,5 mt Barrier balancing spring - 4.5 m Ressort équilibrage barrière 4,5 m Ausgleichsfeder Schranke 4,5 m	Resorte de equilibrio barrera 4,5 m Mola equilibrio barreira 4,5 mt Uitbalanceringsveer barrière 4,5 m.	33 1 34 1 36 2 45 1 46 1 47 1 49 2 50 1 51 1 52 1 54 2 58 1 59 1 62 1
A90239P	Molla bilanciamento barriera 5/6 mt Barrier balancing spring - 5/6 m Ressort équilibrage barrière 5/6 m Ausgleichsfeder Schranke 5/6 m	Resorte de equilibrio barrera 5/6 m Mola equilibrio barreira 5/6 mt Uitbalanceringsveer barrière 5/6 m.	33 1 34 1 36 2 45 1 46 1 47 1 49 2 50 1 51 1 52 1 54 2 58 1 59 1 62 1
A90243P	Staffa supporto finecorsa barriera Limit switch support bracket - Barrier Etrier support fin de course barrière Haltebügel Endschalter Schranke	Elemento soporte final de carrera barrera Suporte de sustentação do fim de curso Barreira Draagbeugel eindschakelaar barrière	6 4 13 2 14 1 15 2
A90245P	Operatore per barriera Modo 800 Barrier operator - Modo 800 Opérateur pour barrière Modo 800 Antrieb für Schranke Modo 800	Dispositivo para barrera Modo 800 Operador para barreira Modo 800 Bedieningsmechanisme voor barrière Modo 800	1 1 2 1 10 1 11 1 12 1 35 2 37 2 42 2 43 2



Gi.Bi.Di. Continental S.p.A. - 46025 Poggio Rusco (MN) - Via A. Brennero 177/B
Tel. ++39.045.8270511 - Fax ++39.045.8270527 - E-mail: comm.gibidi@pn.itnet.it



AUTOMATISMI PROFESSIONALI PER CANCELLI E GARAGE

PARTI DI RICAMBIO - SPARE PARTS - PIECES DE RECHANGE - ERSATZTEILE - PIEZAS DE REPUESTO - VERVANGINGSONDERDELEN - PECAS SOBRESSELENTES

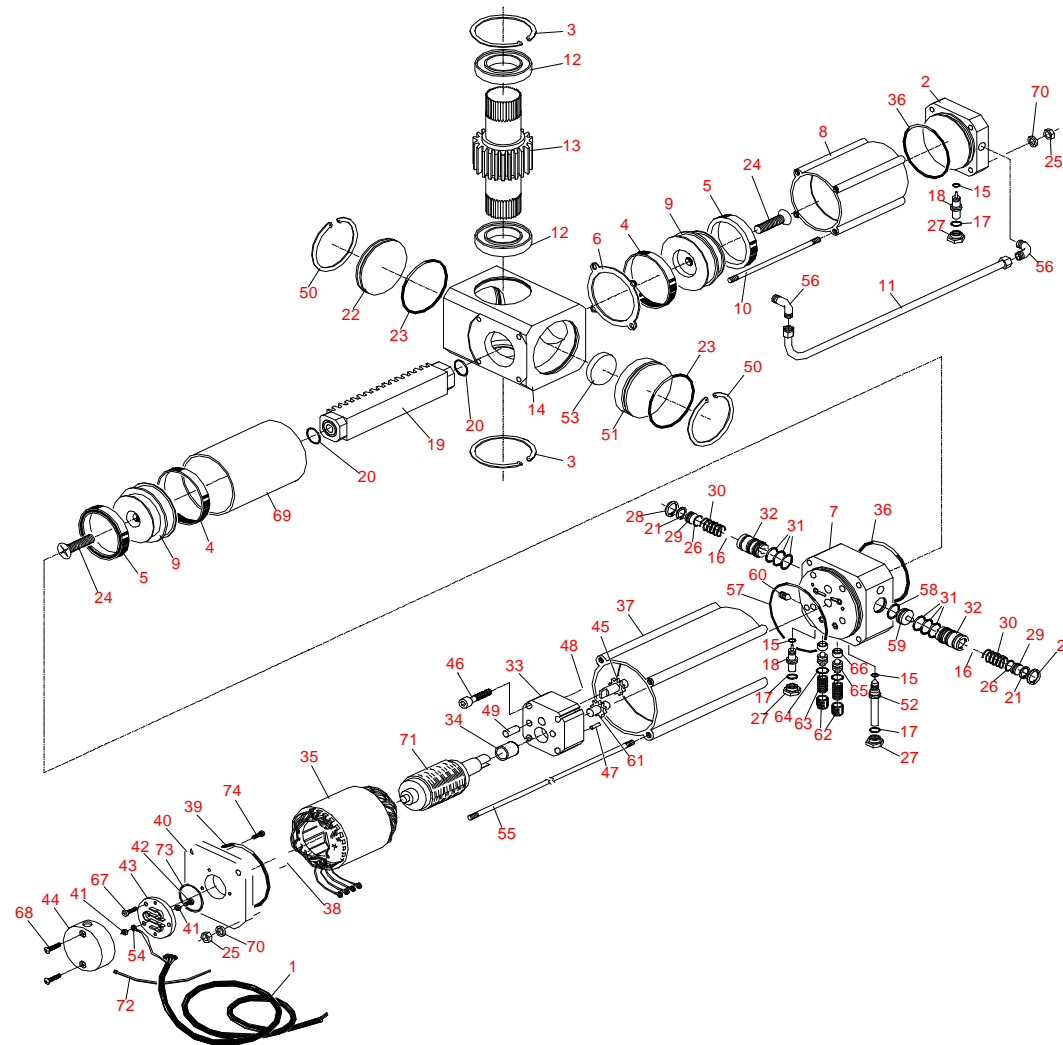

Gi.Bi.Di. Continental S.p.A. - 46025 Poggio Rusco (MN) - Via A. Brennero 177/B
Tel. ++39.045.8270511 - Fax ++39.045.8270527 - E-mail: comm.gibidi@pn.itnet.it



AUTOMATISMI PROFESSIONALI PER CANCELLI E GARAGE

PARTI DI RICAMBIO - SPARE PARTS - PIÈCES DE RECHANGE - ERSATZTEILE - PIEZAS DE REPUESTO - VERVANGINGSONDERDELEN - PECAS SOBRESSELENTES

Cod.	Descrizione Description Description Beschreibung	Descrìpciòn Beschrijving Descrição	
A90126P	Camicia completa martinetto 1010 Complete liner - jack 1010 Chemise complète vérin 1010 komplette Buchse Unterflur-Zylinder 1010	Camisa completa cilindro 1010 Camisa completa macaco 1010 Vijzelmantel compleet 1010	6 1 8 1 36 1
A90128P	Tiranti martinetto 1010 Tie-rods - Jack 1010 Bras de couple vérin 1010 Zugstangen Unterflur-Zylinder 1010	Tirantes cilindro 1010 Tirantes macaco 1010 Trekstangen vijzel 1010	10 8 25 8 26 8
A90190P	Valvola di blocco Modo 500 Check valve - Modo 500 Soupape de blocage Modo 500 Sperrventil Modo 500	Válvula de bloqueo Modo 500 Válvula de bloqueio Modo 500 Blokkeerklep Modo 500	16 1 21 1 26 1 28 1 29 1 30 1 31 1 32 1
A90248P	Testata superiore completa Complete upper end cap Tete supérieure complète kompletter, oberer Kopf	Cabezal superior completo Cabeça superior completa Achterste kop, compleet	2 1 15 1 17 1 18 1 27 1 36 1 56 1
A90249P	Regolatore di flusso Flow regulator Limiteur de débit Flußregler	Regulador de flujo Regulador de fluxo Stromingsregelaar	15 1 17 1 18 1 27 1
A90250P	Pistone completo martinetto barriera Complete piston - barrier jack Piston complet vérin barrière kompletter Kolben Schranke	Pistón completo cilindro barrera Pistão completo macaco barreira Vijzelzuiger barrière, compleet	4 2 5 2 9 2 19 1 20 2 24 2
A90251P	Cilindro inferiore martinetto barriera Lower cylinder - barrier jack - Modo 800 Cylindre inférieur vérin barrière Modo 800 unterer Zylinder Unterflur-Zylinder Schranke	Cilindro inferior cilindro barrera Cilindro inferior macaco barreira Onderste cilinder vijzel barrière	69 1 36 1
A90252P	Corpo martinetto barriera Jack body - Barrier Modo 800 Corps vérin barrière Modo 800 Unterflur-Zylinderkörper Schranke	Cuerpo cilindro barrera Corpo macaco barreira Vijzellichaam barrière	14 1 22 1 23 2 50 2 51 1 53 1
A90253P	Albero uscita martinettobarriera Output shaft - barrier jack - Modo 800 Arbre sortie vérin barrière Modo 800 Abtriebswelle Unterflur-Zylinder Schranke	Eje de salida cilindro barrera Eixo de saída macaco barreira Uitvoeras vijzel barrière	3 2 12 2 13 1
A90254P	Testata inferiore martinetto barriera Complete lower end cap - barrier jack Tete inférieure complète vérin barrière kompletter, unterer Kopf r Schranke	Cabezal inferior completo cilindro barrera Cabeça inferior macaco barreira Onderste kop barrièrevijzel	38 1 39 1 40 1 41 6 42 3 43 1 44 1 67 3 68 2 73 1 74 1
A90255P	Motore completo barriera Modo 800 Complete motor - Barrier Modo 800 Moteur complet barrière Modo 800 kompletter Motor Schranke Modo 800	Motor completo barrera Modo 800 Motor completo barreira Modo 800 Motor compleet barrière Modo 800	35 1 37 1 39 1 57 1 71 1



Gi.Bi.Di. Continental S.p.A. - 46025 Poggio Rusco (MN) - Via A. Brennero 177/B
Tel. ++39.045.8270511 - Fax ++39.045.8270527 - E-mail: comm.gibidi@pn.itnet.it



AUTOMATISMI PROFESSIONALI PER CANCELLI E GARAGE

PARTI DI RICAMBIO - SPARE PARTS - PIECES DE RECHANGE - ERSATZTEILE - PIEZAS DE REPUESTO - VERVANGINGSONDERDELEN - PECAS SOBRESSELENTES

Cod.	Descrizione Description Description Beschreibung	Descrìpçìon Beschrijving Descrição	
A90256P	Pompa completa da 1,14 Lt/min Complete pump - 1.14 l/min. Pompe complète de 1,14 l/min. komplette Pumpe 1,14 l/Min.	Bomba completa de 1,14 l/min Bomba de 1,14 Lt/min completa Pomp 1,14 l/min, compleet	33 1 34 1 45 1 46 4 47 2 48 2 49 2 61 1
A90257P	Distributore completo barriera Modo 800 Complete distributor - Barrier Distributeur complet barrière Modo 800 kompletter Ventilblock Schranke	Distribuidor completo barrera Distribuidor completo barreira Modo 800 Verdeler barrière Modo 800, compleet	7 1 15 2 17 2 18 1 27 2 36 2 52 1 56 1 57 1 58 1 59 1 60 1 62 2 63 2 64 2 65 2 66 2
A90258P	Valvola regolazione pressione barriera Pressure regulating valve - Barrier Limiteur de pression barrière Modo 800 Druckregelungsventil Schranke	Válvula de regulación presión barrera Válvula de regulação de pressão barreira Drukregelklep barrière	62 1 63 1 64 1 65 1 66 1
A90259P	Kit guarnizioni Modo 800 Gasket kit - Modo 800 Kit joints Modo 800 Dichtungssatz Modo 800	Kit guarniciones Modo 800 Kit juntas vedação Modo 800 Pakkingenset Modo 800	4 2 5 2 6 1 15 3 17 3 20 2 23 2 32 6 36 2 39 1 57 1 58 1 64 2 70 2 73 1
A90260P	Cursore di sblocco completo Modo 800 Complete unlocking slider - Curseur de déblocage complet Modo 800 kompletter Entriegelungsschieber	Cursor de desbloqueo completo Cursor de desbloqueio completo Modo 800 Ontgrendelingsschuif Modo 800, compleet	15 1 17 1 27 1 52 1
A90261P	Tubo collegamento martinetto Modo 800 Connection tube - Jack Modo 800 Tuyau de raccordement vérin Modo 800 Verbindungsschlauch Unterflur-Zylinder	Tubo de conexión cilindro Tubo ligação macaco Modo 800 Verbindingsleiding vijzel Modo 800	11 1
A90262P	Tiranti colleg. motore martinetto barriera Motor connection tie-rods - barrier jack Bras de couple moteur verin barrière Zugstangen Verbindung Motor Schranke	Tirantes conexión motor cilindro barrera Tirantes ligação motor macaco barreira Trekstangen verb. motor barrierevijzel	25 4 30 4 70 4



Gi.Bi.Di. Continental S.p.A. - 46025 Poggio Rusco (MN) - Via A. Brennero 177/B
Tel. ++39.045.8270511 - Fax ++39.045.8270527 - E-mail: comm.gibidi@pn.itnet.it

