



ISO 9002 - Cert. n° 0079

Stabilimento e sede:
46025 Poggio Rusco (Mantova) ITALY
Via Abetone Brennero, 177/B
Tel. 0386 522011 - Fax 0386 522031
Tel. 0039 0386 522060 - Fax 0039 0386 522031
E-MAIL: tech.gibidi@pn.itnet.it - comm.gibidi@pn.itnet.it

MOD. "PASS 8" 24V DC GEARMOTOR



INSTRUCTIONS FOR INSTALLATION

GENERAL WARNINGS

These warnings constitute an integral and essential part of the product and must be issued to the user. Carefully read the warnings in this paragraph since they supply important information concerning safety of installation, use and maintenance. Safely keep this handbook for any further consultation.

INSTALLATION WARNINGS

Installation, electrical connections and adjustments must be carried out by qualified technicians in observance of Good Techniques and in compliance with the regulations in force, in accordance with the instructions below. Carefully read the instructions in this handbook before starting installation of the product. Incorrect installation may cause damage to persons, animals or things, for which Gi.Bi.Di. cannot be held responsible. Before connecting the instrument, ensure that the rating indicated on the plate corresponds to that of the mains. Do not install the product in an explosive environment; the presence of inflammable gas or fumes constitute a serious danger. The packaging materials must not be littered and must be kept away from children since they are potential sources of danger. Before starting installation, check that the product is undamaged. Before installing the automation, make the necessary structural modifications relative to safety clearances and protection and/or segregation of the shearing, entrapment and crushing zones, and danger zones in general. Check that the existing structure has the necessary requirements of robustness and stability. Gi.Bi.Di. is not liable for inobservance of Good Techniques in the construction of the doors and gates to be motorized, or in the event of deformations occurring during use. The safety devices (photocell, sensitive frames, emergency stop, etc.) must be installed in consideration of the regulations in force, the installation environment, the functioning logic of the system, and the forces developed by the automatic door or gate. The safety devices must comply with current regulations, and allow protecting any crushing and entrapment zones, and danger zones in general. Each system must visibly be identified (sign, label, etc.) by the product identification data and any automatic remote control commands present. At the time of installation, an omnipolar switch must be fitted with a contact opening distance equal to or greater than 3 mm. Check that upstream of the electrical system a differential switch with a threshold of 0.03A is installed. Connect the automation to an efficient earthing system as provided by the safety regulations in force. Gi.Bi.Di. declines all responsibility for the safety and good functioning of the automation in case the components used in the system are not those specified by the manufacturer.

UTILIZATION WARNINGS This product is intended only for such use for which it was expressly designed. Any other use is to be considered improper and therefore dangerous. Gi.Bi.Di. cannot be held responsible for any damage caused by improper, incorrect and unreasonable use.

The installer must supply all the information relative to manual functioning of the system in case of emergency, and supply the user with the instruction manual. Avoid working near the hinges or moving mechanical devices, which may generate conditions of danger, since the body or garments are easily caught up and difficult to release. Do not enter the range of action of the automatic door or gate while in movement. Wait until it has completely stopped. Do not oppose the motion of the automatic door or gate since this may create dangerous conditions. Do not allow children to play or stand in the vicinity of the automatic door or gate. Keep the radio controls and/ or any other control device out of the reach of children to prevent involuntary activation of the automation.

MAINTENANCE AND REPAIR WARNINGS

In case of breakage and/or bad functioning of the product, switch it off, abstaining from any attempt at repair or direct intervention and contact qualified technicians only. Inobservance of the above may create dangerous conditions. Before carrying out any cleaning, maintenance or repair operations, disconnect the automation from the mains and any emergency batteries. To guarantee efficiency of the system and its proper functioning it is indispensable to follow the instructions of the manufacturer, having the periodical maintenance of the automation carried out by professionally qualified technicians. In particular, it is recommended to periodically check proper functioning of all the safety devices. For any product repairs or replacements, exclusively original spare parts as specified by the manufacturer must be used. Modifications or additions to an existing system must be made following the instructions of the manufacturer and using original parts as specified by the manufacturer. Installation, maintenance and repair operations must be noted on a maintenance card and the card kept by the user.

1. Electrical Connections

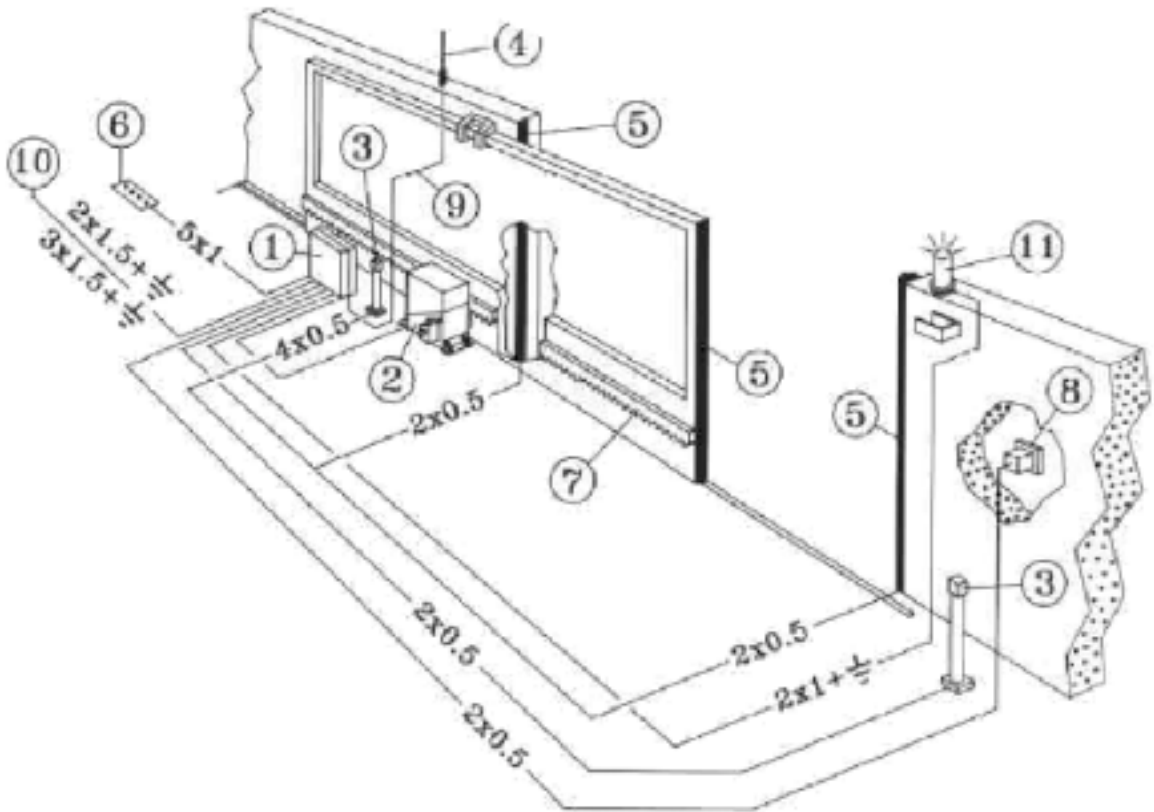

- 1 Electronic equipment container.
- 2 Gearmotor.
- 3 Two pairs of modulated infrared photocells: one internal and one external.
- 4 Antenna.
- 5 Pneumatic strip.
- 6 Push-button panel.
- 7 Rack.
- 8 Key-selector.
- 9 Screened coaxial cable.
- 10 Power supply line to equipment (follow regulations in force).
- 11 220-230 V flashing light.

WARNING: It is important that an omnipolar magneto-thermal switch with a contact opening of minimum 3 mm is installed on the power supply line, upstream of the equipment.

2. Installation of the Gearmotor

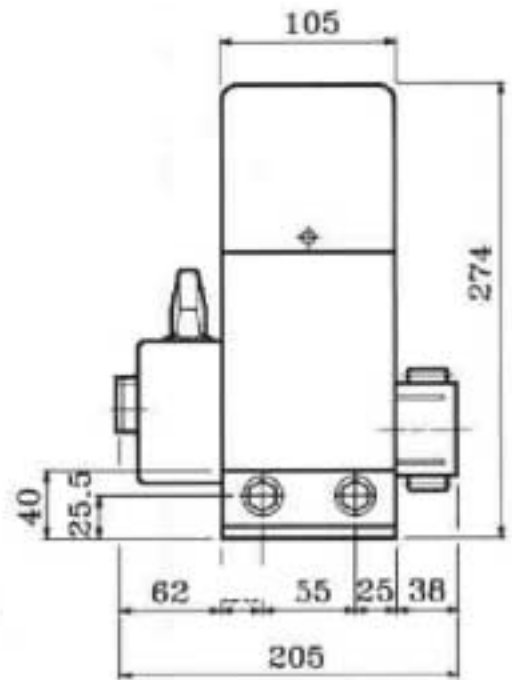
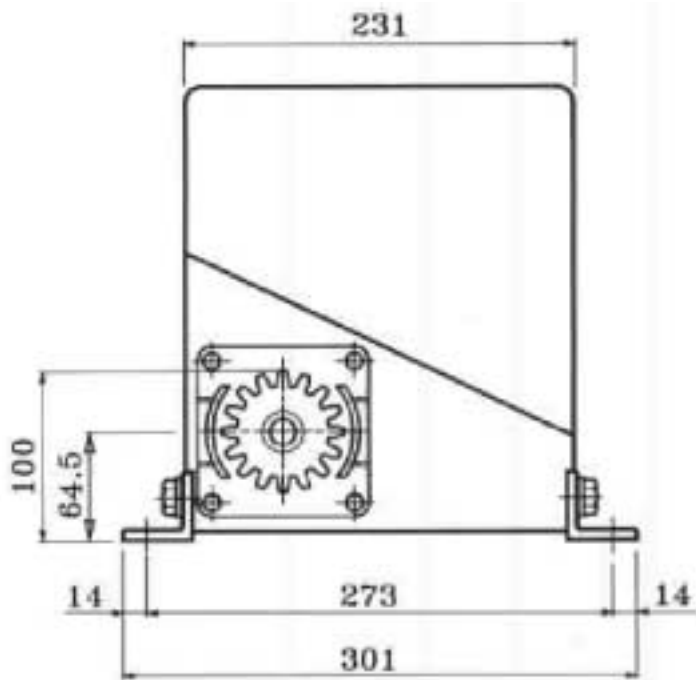

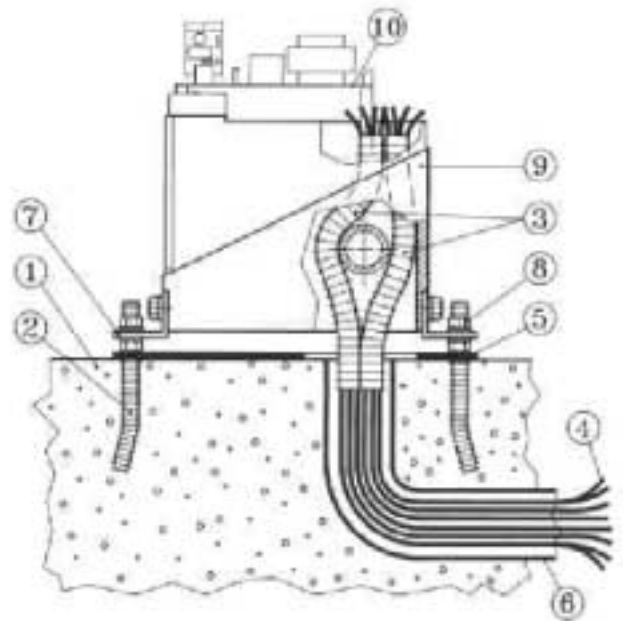
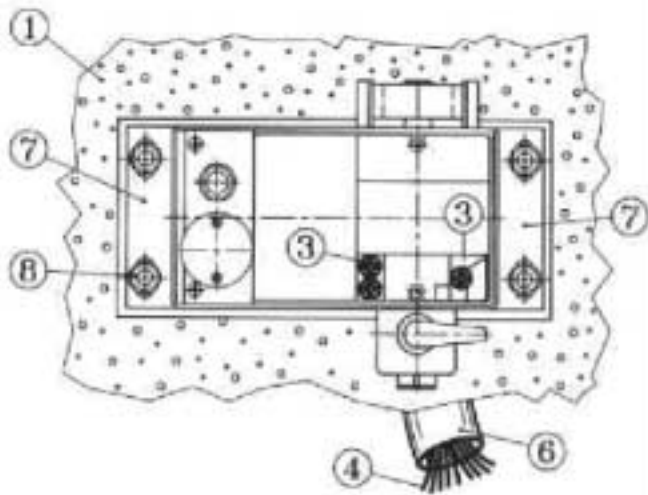
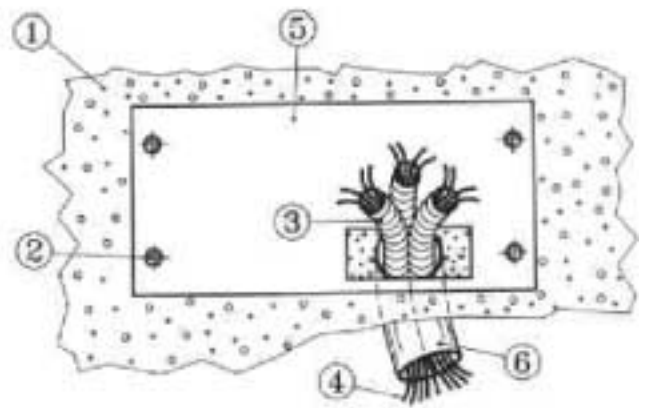
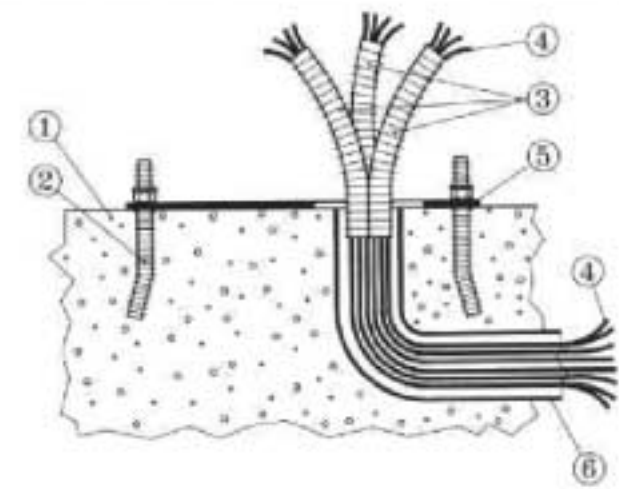

WALLING THE GEARMOTOR FASTENING PLATE

1 Flooring.

2 Feet.

3 Sheaths for cables ϕ 25 minimum. Use approved heavy sheaths of the correct dimensions to protect the cables. The sheaths have to be covered by cement.

4 Electrical cables.

5 Fastening plate which allows the gearmotor height to be adjusted.

6 Tube for laying down the cable.

7 Brackets that allows horizontal adjustment of the gearmotor.

8 Nuts.

9 Gearmotor.

10 Card for connecting the motor and the magnetic lit switches.

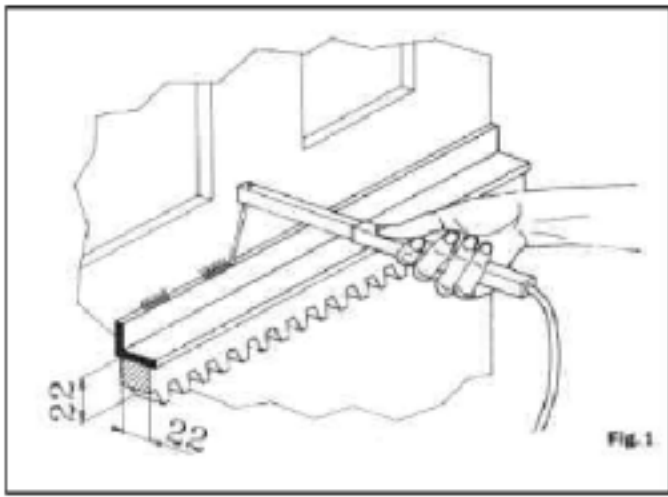

FIG. 1

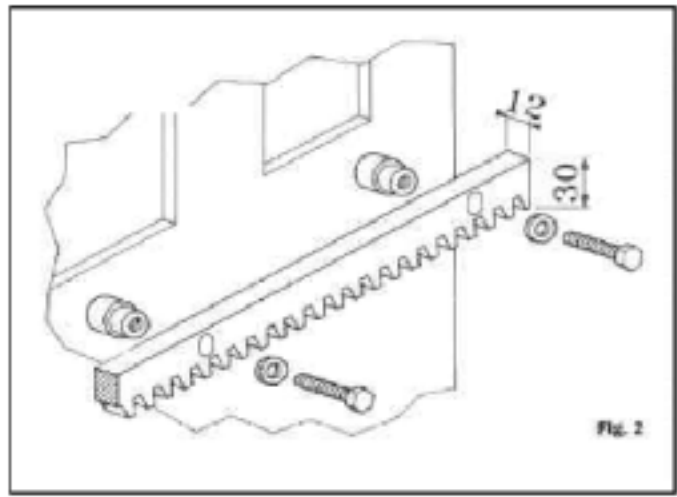

FIG. 2

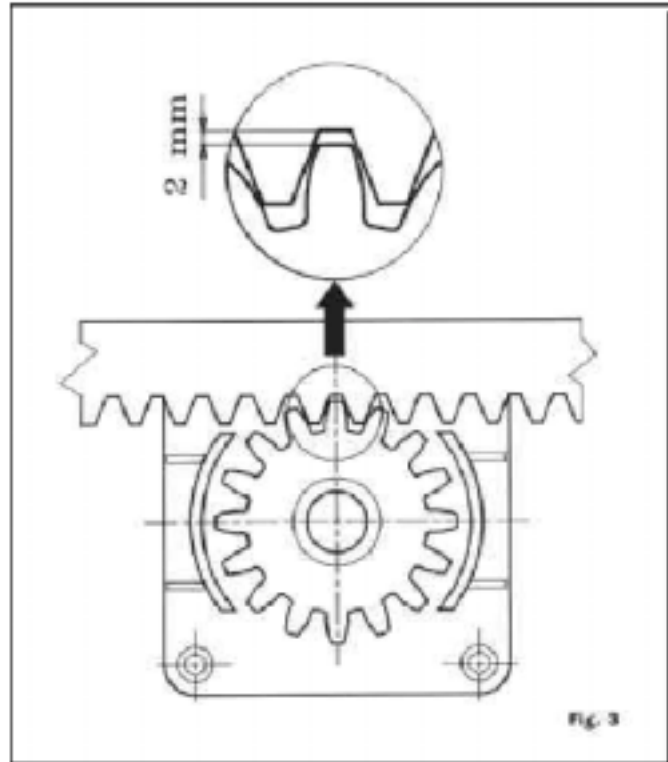

FIG. 3

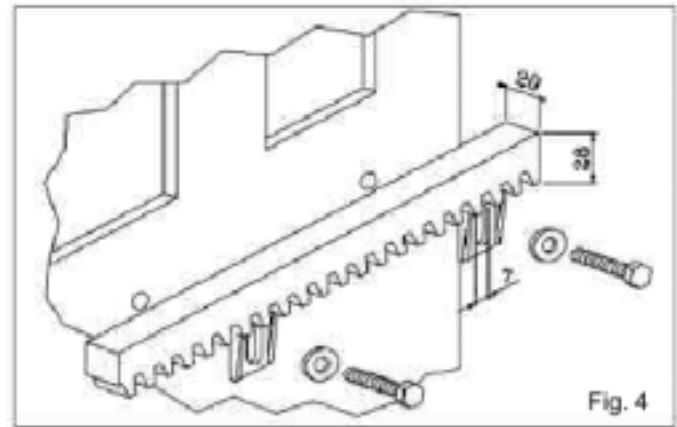

Fig. 4

**Figs. 1, 2 and 4 - Installing the rack -
NOTE: The measurements in the
drawing are in mm.**

INSTALLING THE MAGNETIC LIMIT SWITCHES

Place the two brackets that the magnets (5) are mounted on, above the rack (3) at the two ends of the gate (4) with the gate closed and the gate open in relation to the sensor (1) located above the card. Install the two magnets (2) in a horizontal position on the brackets (5).

NOTE: The distance of the magnets (2) from the gearmotor's cover must not be less than 15 mm.

Place the magnets (2) so that they exactly correspond horizontally with the small magnet (1) installed on the card. The magnets (2) are polarized differently from each other: one has negative polarization and other has positive polarization. Therefore you have to check the installation of the two magnets on the brackets (5). To do this you have to check the stopping points of the gate by manually opening and closing it and using a tester to detect the limit switch wires coming from the card (6) which correspond to the opening and closing. Then connect these wires to the following terminals of the electronic equipment.

NOTE: The measurements in the drawing are in mm.

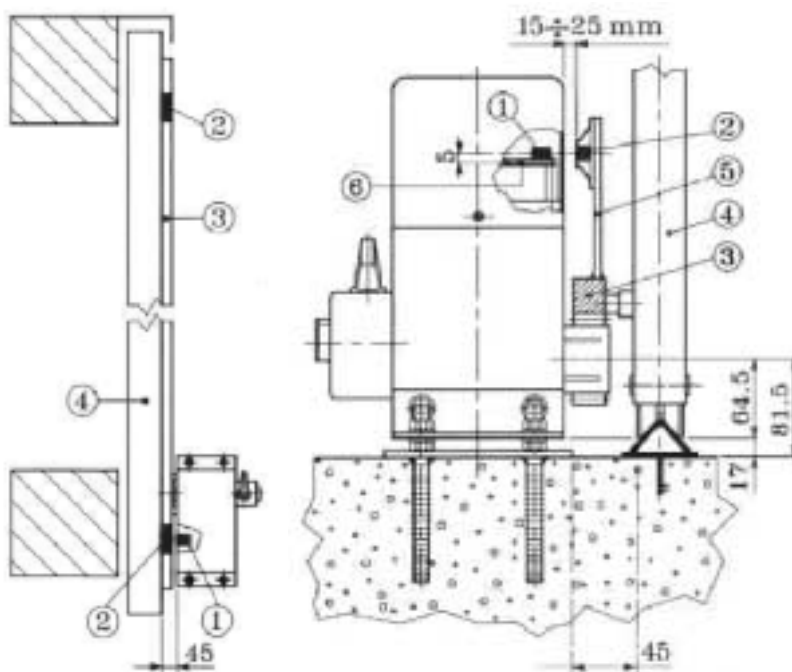

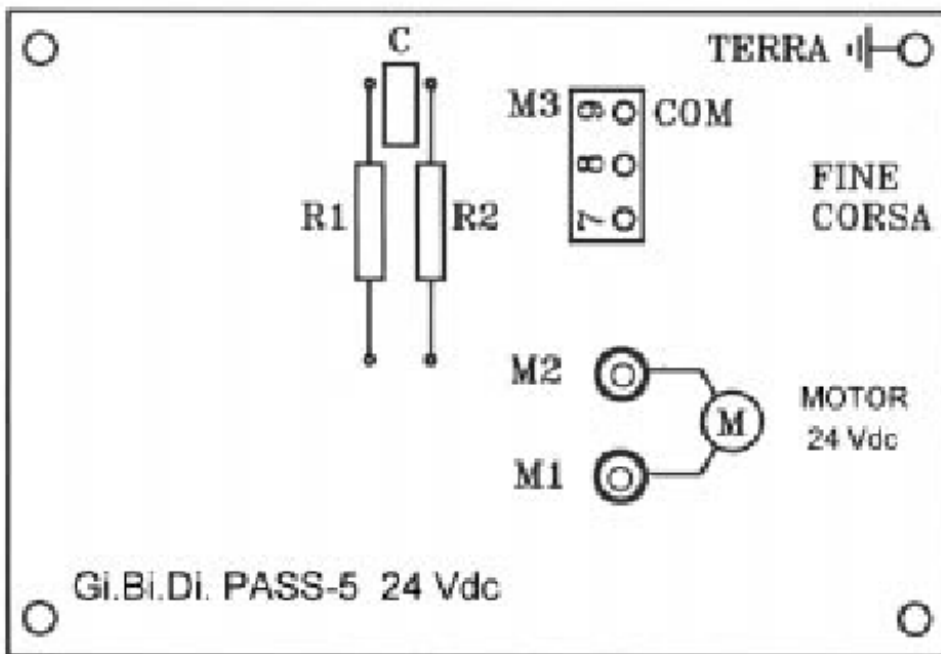

CARDS FOR CONNECTING THE MOTOR AND THE MAGNETIC LIMIT SWITCHES

M1-M2 TERMINAL BOARD for connecting the 24 Vdc motor.

M3 TERMINAL BOARD for connecting the magnetic limit switches. Terminal 9 is the limit switches™ common. The limit switches for opening and closing are based on the gate™s opening direction (if it is right or left). manually operate the gate. Check the opening limit switch and the closing limit switch with a tester on terminal board M3.

R1-R2 Reed limit switch.

C Magnet.

NOTE: It is absolutely necessary to connect the earth.

4. Manual Operation

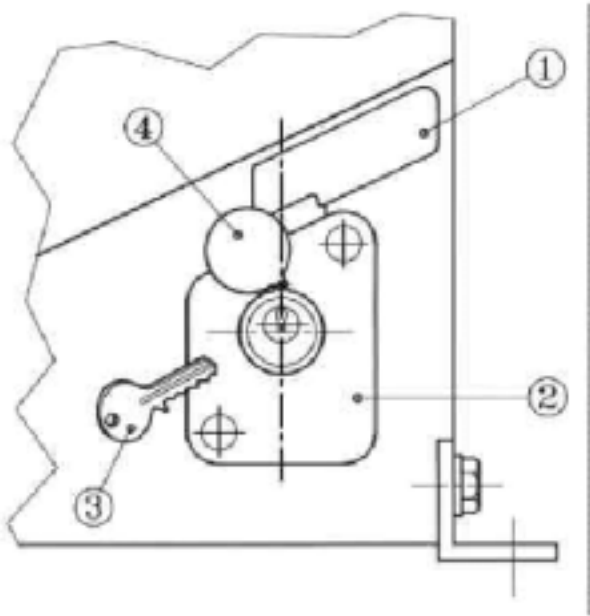

You can manually operate the gate if a problem occurs or if the power supply fails. To manually operate the gate, carry out the following procedure:

rotate the cover (4), insert the key (3), and turn it clockwise (to the right) without forcing it. The key (3) will be pushed out a few millimeters by a spring. Then completely turn the handle (1) 180° towards the left. You can now manually open and close the gate. To automatically reset it, turn the handle (1) to its initial position, push the key (3) forward, turn it counterclockwise (to the left), and then remove it.

NOTE: If the key (3) is not completely pushed forward, it will not turn and cannot be removed.

The handle (1) can even be locked in the manual position by following the above procedure with the key (3).

PASS 8

POWER SUPPLY	24 Vdc
ABSORBED POWER	60 W
ABSORBED CURRENT	4,2 A
PROTECTION AGAINST WETNESS	IP 44
MAX. TORQUE	12 N/m
MAX. SPEED	11 m/s

CE DECLARATION OF CONFORMITY FOR MACHINES

(Directive 89/392 EEC, Attachment II, part B)

PROHIBITION OF OPERATION

The Manufacturer: GiBiDi Continental SRL,

Via Abetone Brennero, 177/B

I-46025 Poggio Rusco (MN)

Declares that the products: **GEARMOTOR "PASS 8"** are constructed to be incorporated in a machine or to be assembled with other machinery to construct a machine considered modified by the Directive 89/392 EEC;

- are not, however, in conformity with all the provisions as per this Directive;

- are in conformity with the regulations of the following other EEC Directives; Directive 73/23 EEC Directive 93/68 EEC - Low voltage Directive 89/336 EEC Directive 92/31 EEC Directive 93/68 EEC - Electromagnetic compatibility

and that

- the following (parts/clauses of) harmonised regulations have been applied:

EN 60335-1 EN 60204-1 EN 55014 EN 61000-3-2
EN 61000-3-3 EN 61000-4-2 ENV 50141 EN
61000-4-4 EN61000-4-5 EN 61000-4-11 EN
55104

- the following (parts/clauses of) national regulations and technical specifications have been applied:

UNI 8612 - Italy

and furthermore, declares that it is not permitted to start operation of the machinery until the machine in which they will be incorporated or of which they will become components has been identified, and its conformity with the provisions of Directive 89/392 EEC and national legislation has been declared, that is to say until the machinery as per this declaration forms a single unit with the final machine.

Poggio Rusco, 1 June 1998

Presidente Tiziano Toselli

