



ISO 9002 - Cert. n° 0079

Stabilimento e sede:

46025 Poggio Rusco (Mantova) ITALY

Via Abetone Brennero, 177/B

Tel. 0386 522011 - Fax 0386 522031

Tel. 0039 0386 522060 - Fax 0039 0386 522031

E-MAIL: tech.gibidi@pn.itnet.it - comm.gibidi@pn.itnet.it

**HYDRAULIC BARRIER "MODO 600" - "MODO 600/V" - "MODO 600/L"
HYDRAULIC BARRIER "MODO 800" FOR HEAVY DUTY SERVICE**

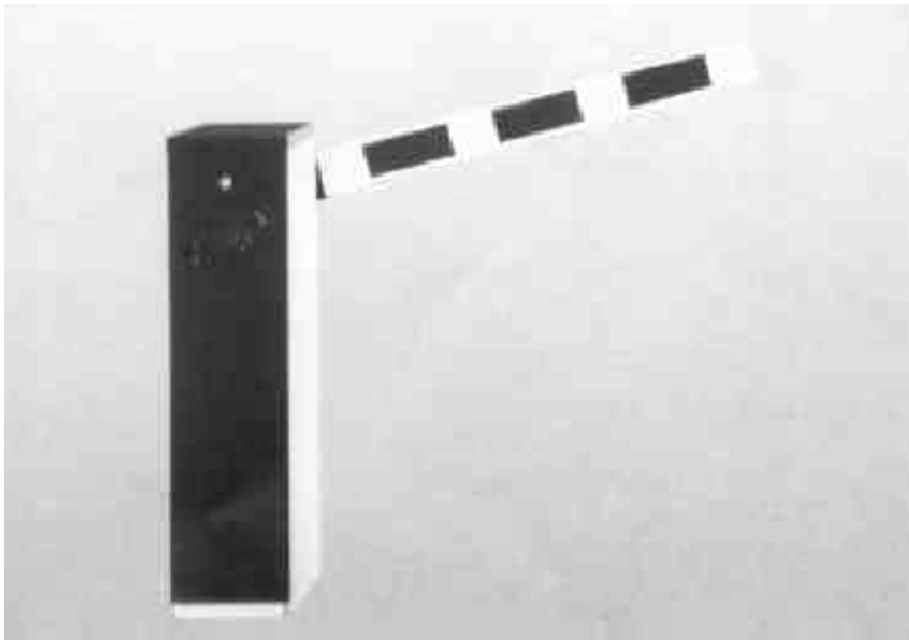

**INSTRUCTIONS FOR
INSTALLATION**

GENERAL WARNINGS

These warnings constitute an integral and essential part of the product and must be issued to the user. Carefully read the warnings in this paragraph since they supply important information concerning safety of installation, use and maintenance. Safely keep this handbook for any further consultation.

INSTALLATION WARNINGS

Installation, electrical connections and adjustments must be carried out by qualified technicians in observance of Good Techniques and in compliance with the regulations in force, in accordance with the instructions below. Carefully read the instructions in this handbook before starting installation of the product. Incorrect installation may cause damage to persons, animals or things, for which Gi.Bi.Di. cannot be held responsible. Before connecting the instrument, ensure that the rating indicated on the plate corresponds to that of the mains. Do not install the product in an explosive environment; the presence of inflammable gas or fumes constitute a serious danger. The packaging materials must not be littered and must be kept away from children since they are potential sources of danger. Before starting installation, check that the product is undamaged. Before installing the automation, make the necessary structural modifications relative to safety clearances and protection and/or segregation of the shearing, entrapment and crushing zones, and danger zones in general. Check that the existing structure has the necessary requirements of robustness and stability. Gi.Bi.Di. is not liable for inobservance of Good Techniques in the construction of the doors and gates to be motorized, or in the event of deformations occurring during use. The safety devices (photocell, sensitive frames, emergency stop, etc.) must be installed in consideration of the regulations in force, the installation environment, the functioning logic of the system, and the forces developed by the automatic door or gate. The safety devices must comply with current regulations, and allow protecting any crushing and entrapment zones, and danger zones in general. Each system must visibly be identified (sign, label, etc.) by the product identification data and any automatic remote control commands present. At the time of installation, an omnipolar switch must be fitted with a contact opening distance equal to or greater than 3 mm. Check that upstream of the electrical system a differential switch with a threshold of 0.03A is installed. Connect the automation to an efficient earthing system as provided by the safety regulations in force. Gi.Bi.Di. declines all responsibility for the safety and good functioning of the automation in case the components used in the system are not those specified by the manufacturer.

UTILIZATION WARNINGS This product is intended only for such use for which it was expressly designed. Any other use is to be considered improper and therefore dangerous. Gi.Bi.Di. cannot be held responsible for any damage caused by improper, incorrect and unreasonable use.

The installer must supply all the information relative to manual functioning of the system in case of emergency, and supply the user with the instruction manual. Avoid working near the hinges or moving mechanical devices, which may generate conditions of danger, since the body or garments are easily caught up and difficult to release. Do not enter the range of action of the automatic door or gate while in movement. Wait until it has completely stopped. Do not oppose the motion of the automatic door or gate since this may create dangerous conditions. Do not allow children to play or stand in the vicinity of the automatic door or gate. Keep the radio controls and/ or any other control device out of the reach of children to prevent involuntary activation of the automation.

MAINTENANCE AND REPAIR WARNINGS

In case of breakage and/or bad functioning of the product, switch it off, abstaining from any attempt at repair or direct intervention and contact qualified technicians only. Inobservance of the above may create dangerous conditions. Before carrying out any cleaning, maintenance or repair operations, disconnect the automation from the mains and any emergency batteries. To guarantee efficiency of the system and its proper functioning it is indispensable to follow the instructions of the manufacturer, having the periodical maintenance of the automation carried out by professionally qualified technicians. In particular, it is recommended to periodically check proper functioning of all the safety devices. For any product repairs or replacements, exclusively original spare parts as specified by the manufacturer must be used. Modifications or additions to an existing system must be made following the instructions of the manufacturer and using original parts as specified by the manufacturer. Installation, maintenance and repair operations must be noted on a maintenance card and the card kept by the user.

1. Electrical Connections

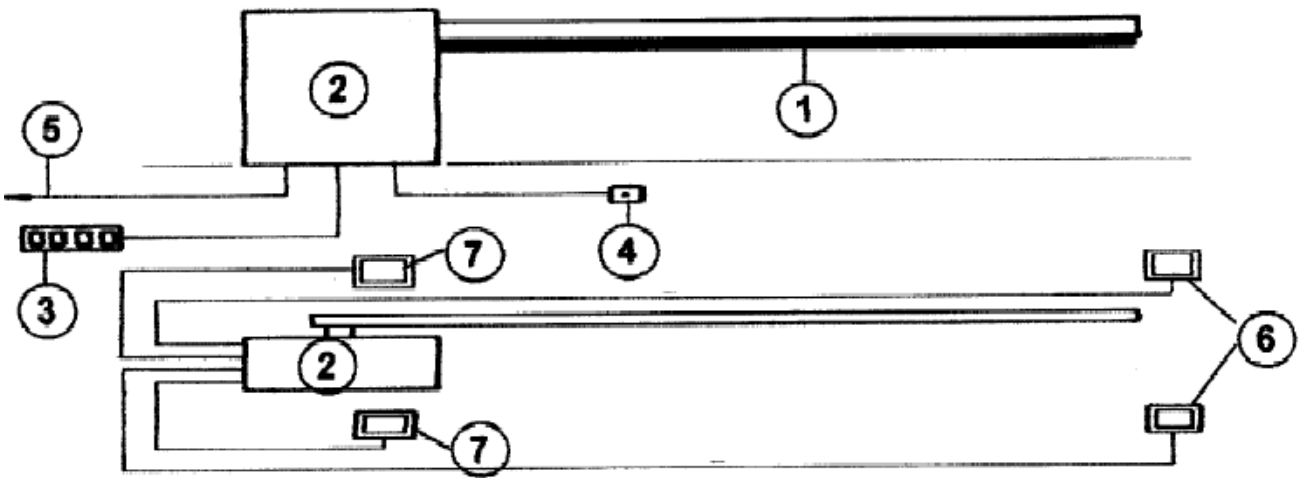

1 Sensitive frame

2 Barrier cabinet 255 x 255 x 1008 mm

3 Push-button panel; cable with 5 conductors of 0.5 mm²

4 Key-selector; cable with 3 conductors of 0.5 mm²

5 Power supply line to control unit 220-230V 50-60Hz; cable with 3 conductors of min. 1.5 mm² (follow regulations in force).

6 Photocell transmitter; cable with 2 conductors of 0.5 mm².

7 Photocell receiver; cable with 4 conductors of 0.5 mm².

WARNING: It is important that an omnipolar magneto-thermal switch with a contact opening of minimum 3 mm is installed on the power supply line, upstream of the control unit.

2. Installation of the Barrier

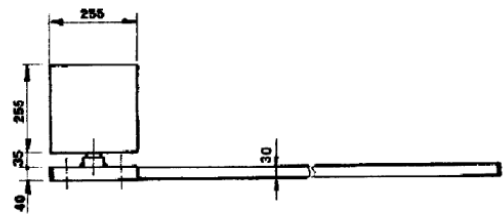
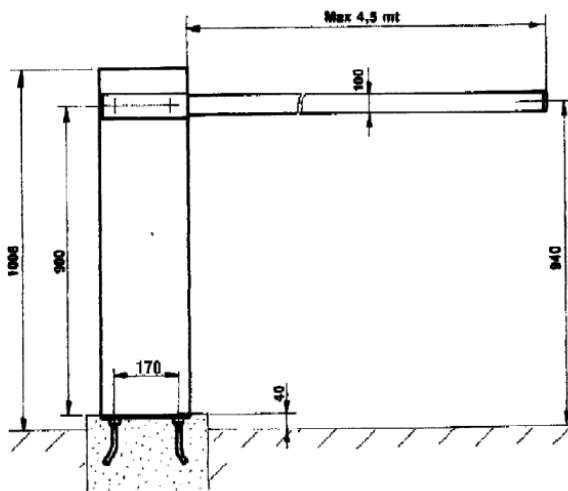
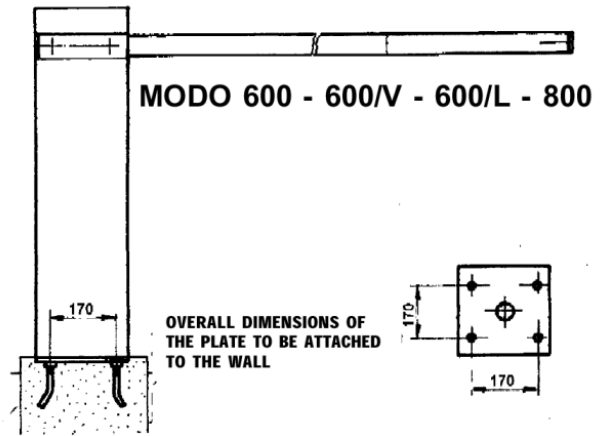

MODO 600 - 600/V

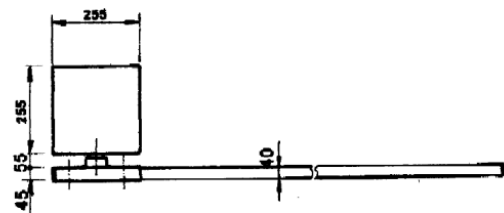
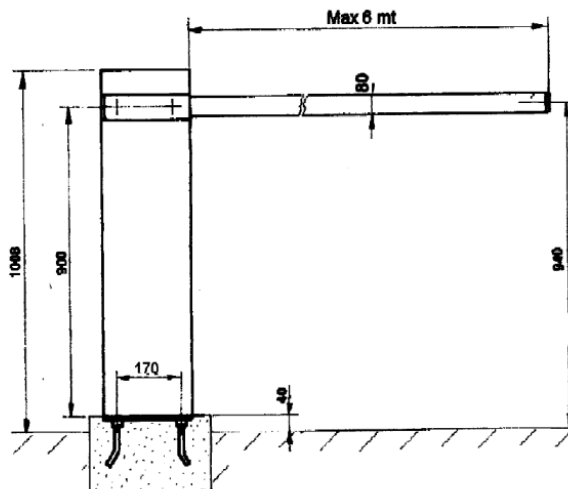

MODO 600/L - 800

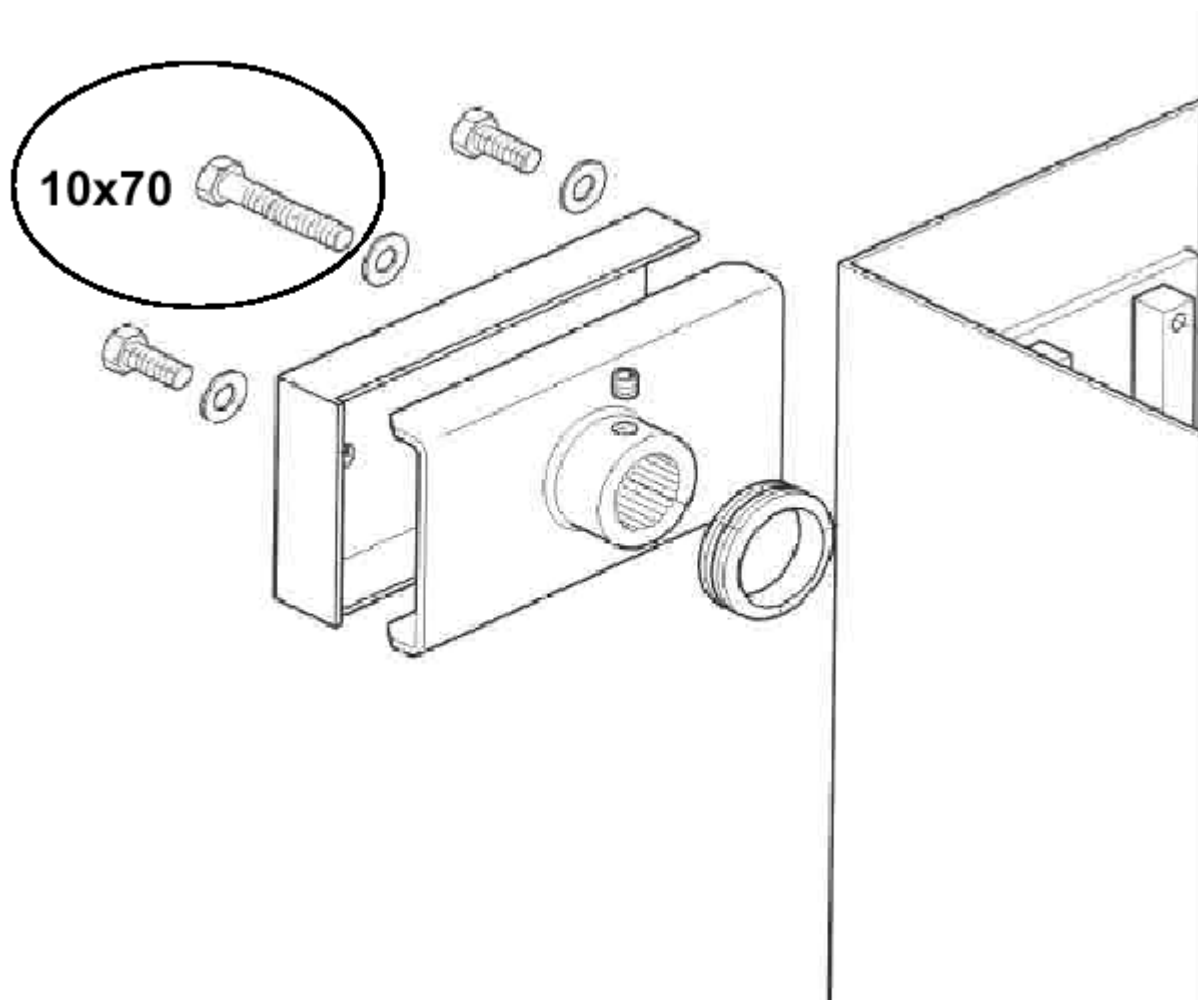

To prevent loosening from occurring due to vibrations in models **MODO 600/L** and **MODO 800**, tighten well the 10 x 70 bolt that attaches the arm support to the jack's shaft (shown in the figure) and apply some thread locking compound on the bolt (for example, Loctite 242 – medium thread locking compound).

MODO 600 - 600/V

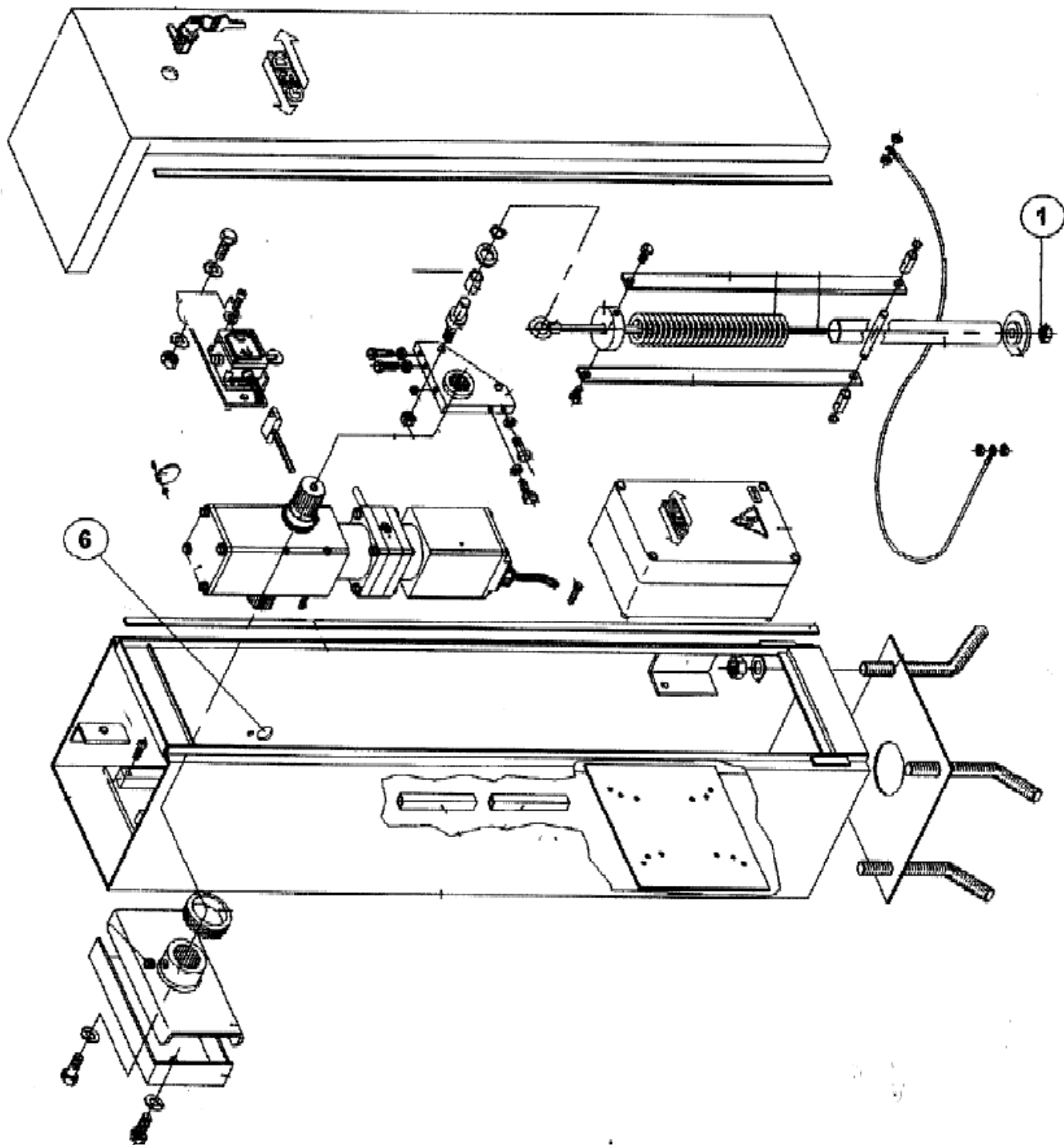

MODO 600/L

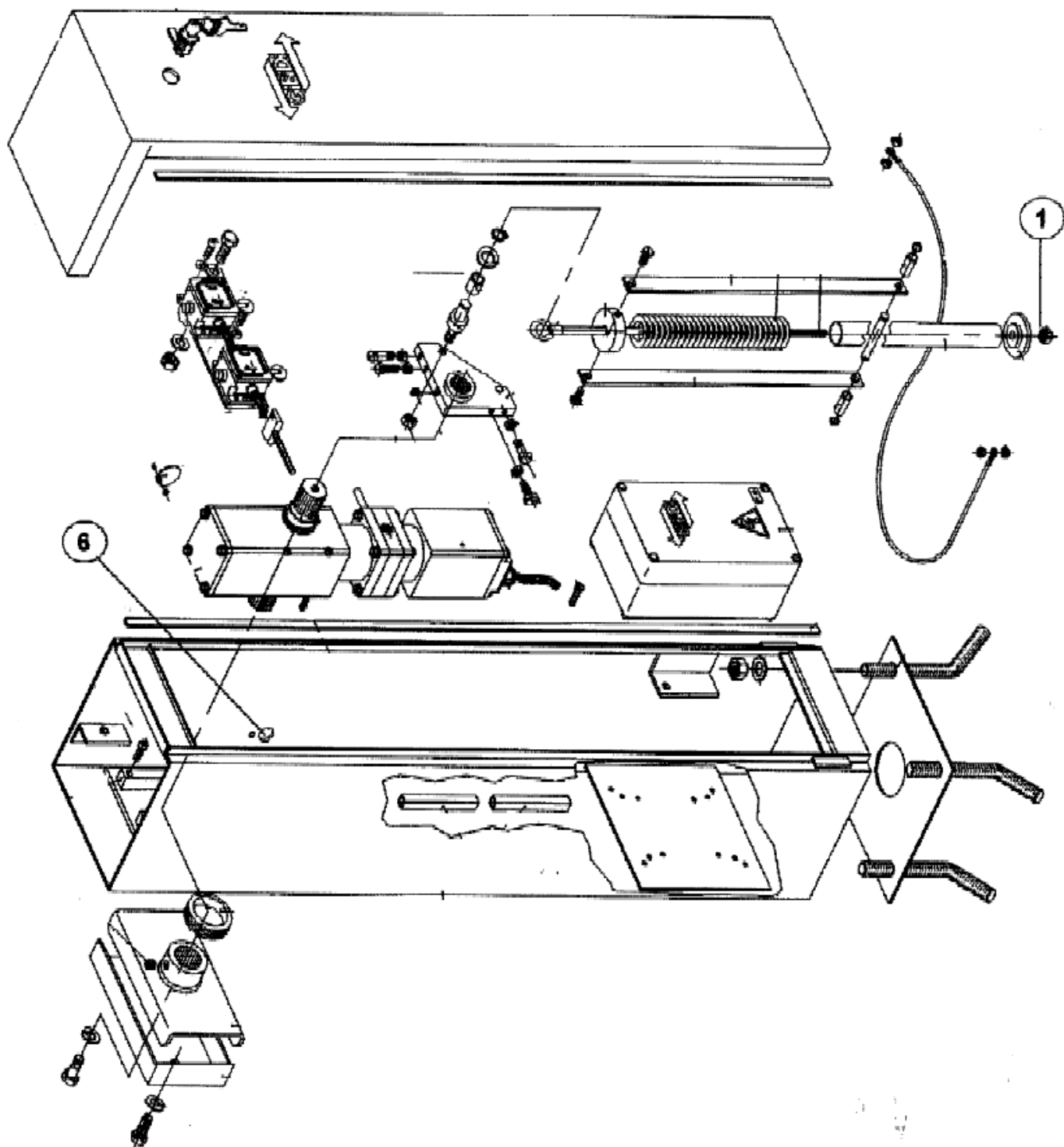

MODO 800

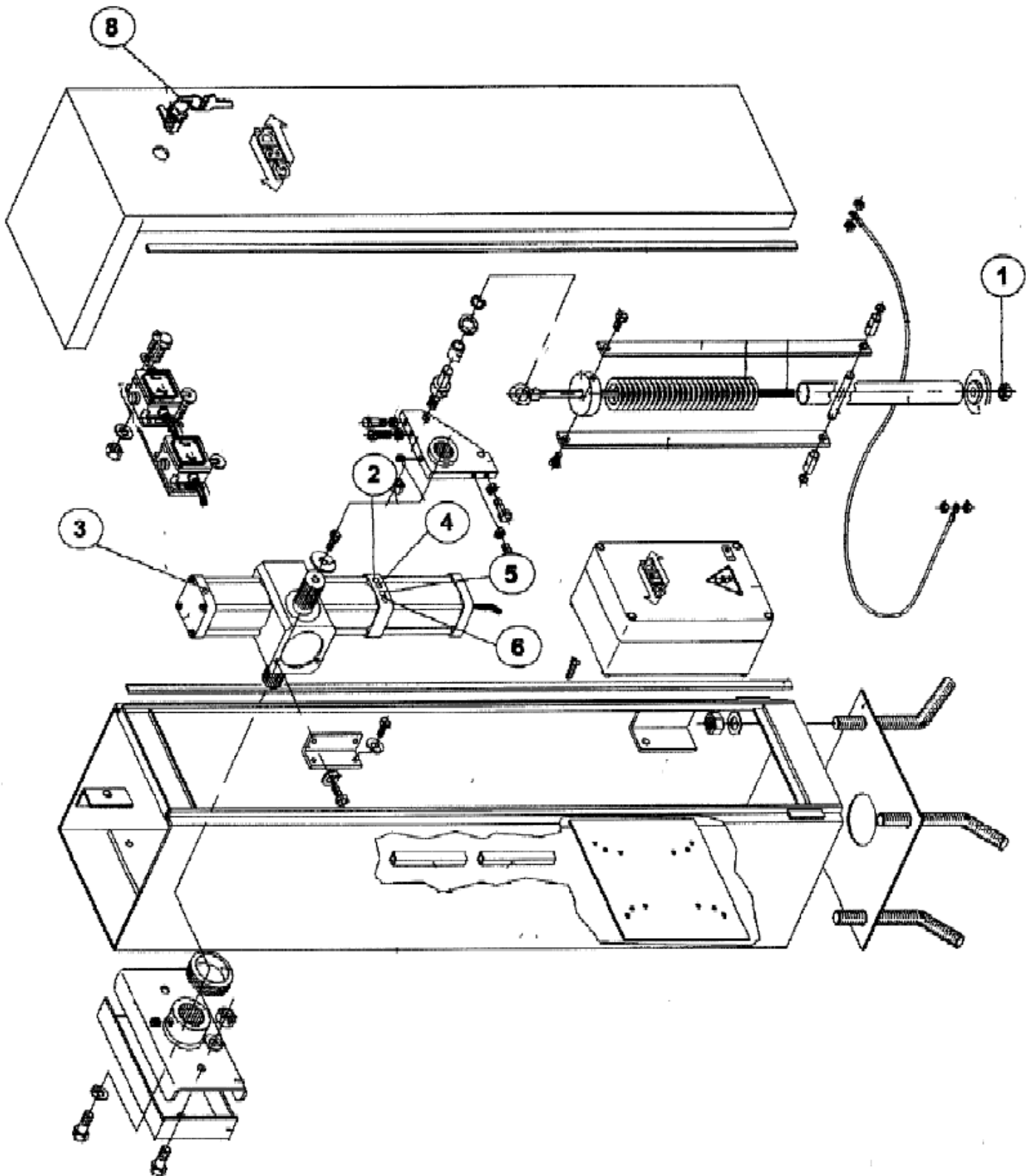

SEE PAGES 6-7-8

1 Nut for the adjustment of the arm balancing spring; screwing the nut balancing force increases, unscrewing it the balancing force decreases.

2 (ONLY FOR MODO 800) Opening speed adjustment device with right-type barrier, closing speed adjustment with left-type barrier; rotating clockwise the speed decreases, rotating anticlockwise the speed increases.

3 (ONLY FOR MODO 800) Closing speed adjustment device with right-type barrier, opening speed adjustment with left-type barrier; rotating clockwise the speed decreases, rotating anticlockwise the speed increases.

4 Opening force adjustment device with right-type barrier, closing force adjustment with left-type barrier; rotating the screw clockwise the force increases, rotating it anticlockwise the force decreases.

5 Closing force adjustment device with right-type barrier, opening force adjustment with left-type barrier; rotating the screw clockwise the force increases, rotating it anticlockwise the force decreases.

4. Manual Operation

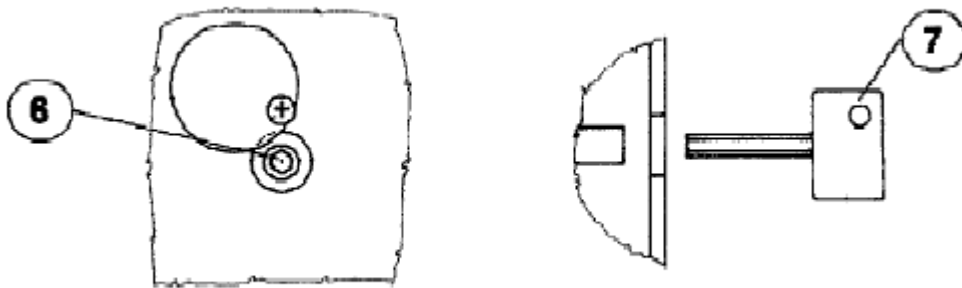

MODO 600 - 600/V - 600/L

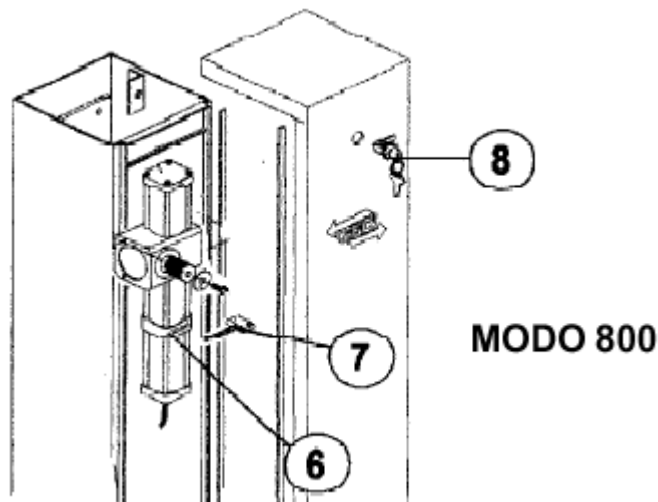

MODO 800

MODO 600 - 600/V - 600/L

A) Insert the key (7) in the unlocking device (6); rotate the key counter-clockwise at least one turn without forcing it, then carry out the manual operation.

B) To automatically reset it, rotate the key (7) completely clockwise.

MODO 800

A) Take away the cabinet cover with the personalized key (8), insert the key (7) in the unlocking device (6); rotate the key counter-clockwise at least one turn without forcing it, then carry out the manual operation.

B) To automatically reset it, rotate the key (7) completely clockwise; lock the cabinet with the personalised key (8).

WARNING: carry out the manual operation with the motor stopped.

5. Technical Features

	600	600/V	600/L	800
Power Supply	220 – 230 V	220 – 230 V	220 – 230 V	220 – 230 V
Absorbed Power	185 W	185 W	185 W	209 W
Absorbed Current	0.77 A	0.77 A	0.77 A	0.97 A
Capacitor	6.3 uF	6.3 uF	6.3 uF	6.3 uF
Max. Arm Length	4.5 m	3 m	6 m	6 m
Time to Open up	7 s	3 s	7 s	7 s
Working Temperature	-30 C +80 C	-30 C +80 C	-30 C +80 C	-30 C +80 C
Use	Not Intensive	Not Intensive	Not Intensive	Intensive
Hydraulic Oil	LHM / SHELL EB - Q - 07		LHM / SHELL EB - Q - 07	

CE DECLARATION OF CONFORMITY FOR MACHINES

(Directive 89/392 EEC, Attachment II, part B)

PROHIBITION OF OPERATION

The Manufacturer: GiBiDi Continental SRL,

Via Abetone Brennero, 177/B

I-46025 Poggio Rusco (MN)

Declares that the products: **HYDRAULIC BARRIER “MODO 600” - “MODO 600/V” - “MODO 600/L” - “MODO 800”**

- are constructed to be incorporated in a machine or to be assembled with other machinery to construct a machine considered modified by the Directive 89/392 EEC;

- are not, however, in conformity with all the provisions as per this Directive;

- are in conformity with the regulations of the following other EEC Directives; Directive 73/23 EEC Directive 93/68 EEC - Low voltage Directive 89/336 EEC Directive 92/31 EEC Directive 93/68 EEC - Electromagnetic compatibility

and that

- the following (parts/clauses of) harmonised regulations have been applied:

EN 60335-1 EN 60204-1 EN 55014 EN 61000-3-2
EN 61000-3-3 EN 61000-4-2 ENV 50141 EN
61000-4-4 EN61000-4-5 EN 61000-4-11 EN
55104

- the following (parts/clauses of) national regulations and technical specifications have been applied:

UNI 8612 - Italy

and furthermore, declares that it is not permitted to start operation of the machinery until the machine in which they will be incorporated or of which they will become components has been identified, and its conformity with the provisions of Directive 89/392 EEC and national legislation has been declared, that is to say until the machinery as per this declaration forms a single unit with the final machine.

Poggio Rusco, 1 June 1998

Presidente Tiziano Toselli

